



Table of contents

1. INTRODUCTION	3
2. CALCULATIONS BASED ON LUMINANCE	3
2.1 EXPLANATIONS FOR THE CALCULATION	3
2.1.1 Geometrical Calculations	4
2.1.2 Photometric Calculations	4
2.1.3 Energy Calculations	5
2.1.4 Electrical Calculations	6
2.1.5 Details about the tolerance limit	7
3. CALCULATIONS BASED ON ILLUMINANCE	9
3.1 EXPLANATIONS FOR THE CALCULATION	9
3.1.1 Geometric Calculations	9
3.1.2 Photometric Calculations	10
3.1.3 Energy Calculations	10
3.1.4 Electrical Calculations	11
3.1.5 Details about the tolerance limit	12
4. CALCULATIONS BASED ON LUMINOUS INTENSITY	13
4.1 EXPLANATIONS FOR THE CALCULATION	13
4.1.1 Geometric Calculations	13
4.1.2 Photometric Calculations	13
4.1.3 Energy Calculations	14
4.1.4 Electrical Calculations	16
4.1.5 Details about the tolerance limit	17
5. CALCULATIONS BASED ON REMISSION	18
5.1 EXPLANATIONS FOR THE CALCULATION	18
5.1.1 Geometric Calculations	18
5.1.2 Photometric Calculations	19
5.1.3 Energetische Berechnungen	20
5.1.4 Electrical Calculations	20
5.1.5 Details about the tolerance limit	21

Table of figures

FIGURE 1: CALCULATION BASICS FROM LUMINANCE TO DIODE CURRENT	3
FIGURE 2: SIMPLIFIED DEMONSTRATION OF A VOLTAGE DIVIDER	8
FIGURE 3: CALCULATION BASICS FROM ILLUMINANCE TO DIODE CURRENT	9
FIGURE 4: CALCULATION BASICS FROM LUMINOUS INTENSITY TO DIODE CURRENT	13
FIGURE 5: CALCULATION BASICS FROM REMISSION TO DIODE CURRENT	18

Sensor Signal Measurement Chain

List of tables

TABLE 1: LUMINANCE: GEOMETRICAL PARAMETERS	4
TABLE 2: LUMINANCE: PHOTOMETRICAL PARAMETERS	5
TABLE 3: LUMINANCE: ENERGY PARAMETERS	5
TABLE 4: LUMINANCE: ELECTRICAL CALCULATIONS	6
TABLE 5: PARAMETER CALCULATIONS FOR: TIA DIRECTLY CONNECTED TO VREF	7
TABLE 6: PARAMETER CALCULATIONS FOR: TIA AT LOWER VOLTAGE AS VREF	7
TABLE 7: ILLUMINANCE: GEOMETRICAL PARAMETERS	9
TABLE 8: ILLUMINANCE: PHOTOMETRICAL PARAMETERS	10
TABLE 9: ILLUMINANCE: ENERGY PARAMETERS.....	10
TABLE 10: ILLUMINATION: ELECTRICAL CALCULATIONS	11
TABLE 11: LUMINOUS INTENSITY: GEOMETRICAL PARAMETERS	13
TABLE 12: LUMINOUS INTENSITY: PHOTOMETRICAL PARAMETERS	14
TABLE 13: LUMINOUS INTENSITY: ENERGY PARAMETERS	14
TABLE 14: LUMINOUS INTENSITY: ELECTRICAL CALCULATIONS	16
TABLE 15: REMISSION: GEOMETRICAL PARAMETERS	19
TABLE 16: REMISSION: PHOTOMETRICAL PARAMETERS	19
TABLE 17: REMISSION: ENERGY PARAMETERS	20
TABLE 18: REMISSION: ELECTRICAL CALCULATIONS	21

Sensor Signal Measurement Chain

1. Introduction

This document describes the handling of the xls- file for calculating the optimized sensor- and amplification parameters for different applications of colorimetric monitor measurements. The major task is the detection of very small signals and the conditioning. For this, there are existing two methods. On the one hand there is a signal conditioning by a transimpedance amplifier and on the other hand there is a signal conditioning with a current charge converter (analog to the transimpedance amplifier, but there is a feedback capacitor). After chapters serve for simulation of different calculations based on JENCOLOR sensors. With the aid of the following formulas theoretical parameters can be calculate, which could be accepted for guideline values of practice. Sensor specific values are performed in the several data sheets.

2. Calculations based on luminance

A typical example to show the interrelationships of the calculation basics are shown the following picture (figure 1).

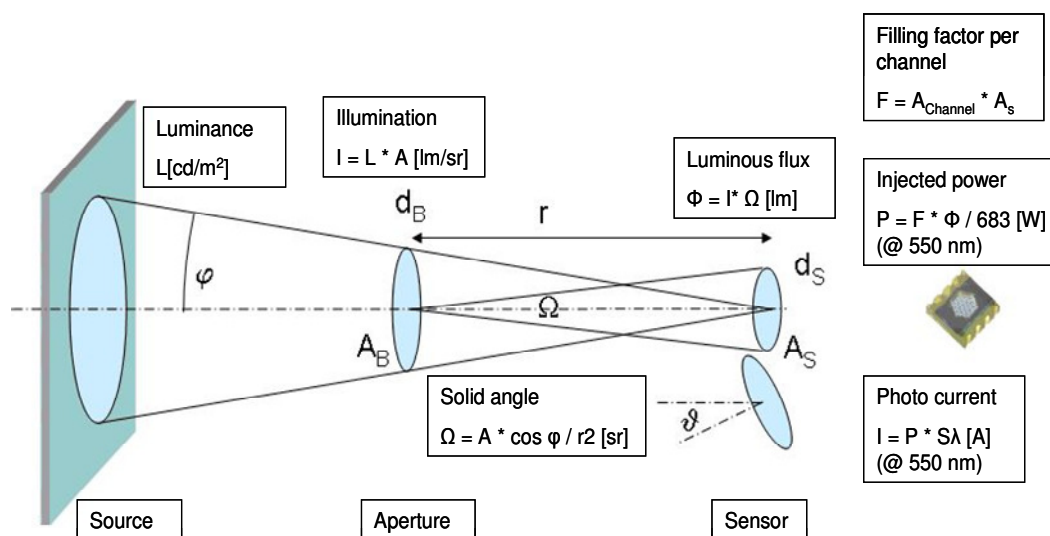

figure 1: calculation basics from luminance to diode current

2.1 Explanations for the calculation

This Chapter explains the several areas of the Excel sheet together with its functions. The several Chapters are structured into the following points for a better understanding. The underlined values could be changed for a better practical result. The remaining values are several fix or they are recalculated after changing the underlined ones.

Sensor Signal Measurement Chain

2.1.1 Geometrical Calculations

Fix values of table 1 are the sensor diameter $d(\text{Sensor})$ and the resulting sensor area $A(\text{Sensor})$ out of it. All other values are calculated after the manual input of the following parameters; aperture diameter $d(\text{aperture})$ and the distance between the sensor and the aperture $r(\text{sensor-aperture})$.

Geometric Calculations

$d(\text{aperture})$	d_B	<u>2,3</u> mm
$A(\text{aperture})$	A_B	4,15265 mm ²
$r(\text{sensor-aperture})$	r	<u>14</u> mm
Beam width	φ	9,5 °
$d(\text{sensor})$	d_s	<u>2</u> mm
$A(\text{sensor})$	A_s	3,14 mm ²

table 1: luminance: geometrical parameters

The conversion of the color filtering is based on interference filters which had a defined combination of low and high refracting thicknesses. In case of non vertical incident light the optical path through the interference filter thicknesses is longer. So that, another composition of the interference, different to vertical incident light, is possible. Note, that the beam width φ should be smaller than 10°.

$$\varphi = \arcsin \frac{\text{aperture diameter}}{r_{(\text{sensor-aperture})}} \quad [^\circ] \quad (1)$$

2.1.2 Photometric Calculations

Changeable values of the photometric calculations are luminance and sensor dumping.

Regarding to expanded light sources, the luminescent area corresponds to the aperture level. I.e. the principle adjustment with a fix aperture is independent from the distance to the luminance area.

The luminance of the aperture area (A_B) is combined to an idealized point source whose uniformly distributed illumination is radiating to the sensor adjusted half space. From this illumination the luminous flux of the sensor, which is located in the solid angle Ω , can be calculated. The solid angle is the result of the following equation: (ϑ is the sensor dumping)

$$\Omega = \frac{A(\text{sensor}) \cdot \cos \vartheta}{(r_{\text{sensor-aperture}})^2} \quad [\text{sr}] \quad (2)$$

Sensor Signal Measurement Chain

Photometric Calculations

Luminance	L	<u>200</u> cd/m ²
		8,3053E-
Illumination	I	04 lm/sr
Solid angle	Ω	0,01602 sr
Sensor dumping	ϑ	<u>0,00</u> °
		2,6611E-
Luminous flux	Φ	05 lm

table 2: luminance: photometrical parameters

2.1.3 Energy Calculations

The different parameter values: filling factor, mean spectral sensitivity and RGB- segmentation of the spectrum via filters are sensor specific parameters.

The filling factor is the ratio of the whole sensor area (A_s) and the area of the chosen diode. The filling factor is formed (in case of the MTCSi) of three diode channels, each with an area of 25 % of the whole area, and 25 % of non photosensitive structures.

The RGB- segmentation value (40 %) is allowed for the filter effects, which are coupling only a spectral part from approx. 40 % into the photodiodes. The value of the mean spectral sensitivity results from the sensor specific data sheet.

Energy Calculations

Filling factor	F	<u>25%</u>
Injected power	P	2,8242E-07 W
RGB- segmentation of the filters	T	<u>40%</u>
Mean spectral sensitivity	S	<u>0,3</u> A/W
Photo current	I	3,3891E-08 A

table 3: luminance: energy parameters

The injected power P at one diode channel is the result of the multiplication from the luminous flux to the sensor area and the sensor specific filling factor. Additional to this, the result is divided by the luminous efficacy of radiation (683 lm/W) to convert the photometrical value into a physical one.

Sensor Signal Measurement Chain

The photo current is the result of the multiplication from injected power, mean spectral sensitivity and RGB- segmentation. Because of some simplifications in the following equations the results are as only approximations.

2.1.4 Electrical Calculations

Individually adjustable parameters are the resistor value, possibly the re-amplification, the reference voltage of the ADC and the resolution of the ADC.

Electrical Calculations

Analysis of the Current-Charge Converter

Capacitance	C	5,00E-11 F
Integration time	t	0,01 s
Voltage difference	U(int)	2,34E-01 V

Analysis of the TIA

Reference voltage of the ADC	VREF	2,500 V
Resistor value	R	20.000.000 Ohm
Re-amplification	N	50

Voltage after TIA	VTIA	2,477 V
Voltage difference	ΔV	0,023 V
Output voltage	VOUT	1,169 V

ADC resolution	Res	12 bit
Reference voltage	Vref	2,5 V
digital value	ADC-Value	1915 Digits

table 4: luminance: electrical calculations

The signal voltage after the TIA is the result from the multiplication from the resistor value and the injected photo current (Chapter 2.1.3). The result out of the inverted resistor amplification function and an increasing diode current is a decreasing voltage level proportional to the reference voltage value. The following amplification stage should be configured as a differential amplifier. Note that the output voltage shouldn't leave the workspace of the ADC.

The following formula was the calculation basic for the digital values. (The result was rounded down):

$$\text{ADCValue} = \left(\frac{\text{Output Voltage}}{\text{Reference Voltage}} \right) * 2^{\text{ResolutionADC}} \quad [\text{Digits}] \quad (3)$$

Sensor Signal Measurement Chain

At method with the current charge converter only the capacitor value and the integration time could be changed individually by the user. The resulting voltage difference (U_{int}) is calculated by:

$$U_{\text{int}} = \frac{I * t}{C} \quad [\text{V}] \quad (4)$$

2.1.5 Details about the tolerance limit

The tolerance limit analysis of the xls- file is classified into two parts. On the one hand electrical parameter calculations if the TIA is directly connected to Vref (table 5) and on the other hand there are the same calculations with a voltage divider, which generates a separate reference voltage with reduced offset (table 6).

TIA directly connected to VREF			-0,01 V	0,01 V
dark signal after TIA	VTIA	2,500 V	2,490 V	2,510 V
voltage difference to VREF	ΔV	0,000 V	0,010 V	-0,010 V
output voltage 1Dark	VOUT	0,000 V	0,500 V	-0,500 V
voltage signal after TIA	VTIA	2,477 V	2,467 V	2,487 V
voltage difference	ΔV	0,023 V	0,033 V	0,013 V
output voltage 1	VOUT	1,169 V	1,669 V	0,669 V

table 5: parameter calculations for: TIA directly connected to Vref

The blue marked values of table 5 represents the respective offset values of the TIA. These values were added or subtracted from the respective signal value after the TIA. If some cells were marked with red color, the reason is an overstepping of the voltage borders from 0 V to 2.5 V. For comparison in the high-light state the dark signal values and the measured values were illustrated. The result of the multiplication from the voltage differences with the re- amplified resistor value is the output voltage value in table 5. The calculation of the output voltage value after the TIA is analog.

TIA at lower voltage as VREF					
voltage divider	R4	3900 Ω			
voltage divider	R2	33 Ω			
reference voltage at TIA	Vref(TIA)	2,479 V			
dark signal after TIA	VTIA	2,479 V	2,469 V	2,489 V	
voltage difference to VREF	ΔV	0,021 V	0,031 V	0,011 V	
output voltage 1Dark	VOUT	1,049 V	1,549 V	0,549 V	
voltage signal after TIA	VTIA	2,456 V	2,446 V	2,466 V	
voltage difference for ADC	ΔV	0,044 V	0,054 V	0,034 V	
output voltage	VOUT	2,218 V	2,718 V	1,718 V	

table 6: parameter calculations for: TIA at lower voltage as Vref

Sensor Signal Measurement Chain

Individually adjustable parameters of table 6 are both resistor values R_4 and R_2 (red values) of the voltage divider. The resistor values could be changed until the result is optimized (figure 2). In use of the reduced reference voltage maybe it is possible to set component specific offsets to the workspace of the re- amplifier and the ADC.

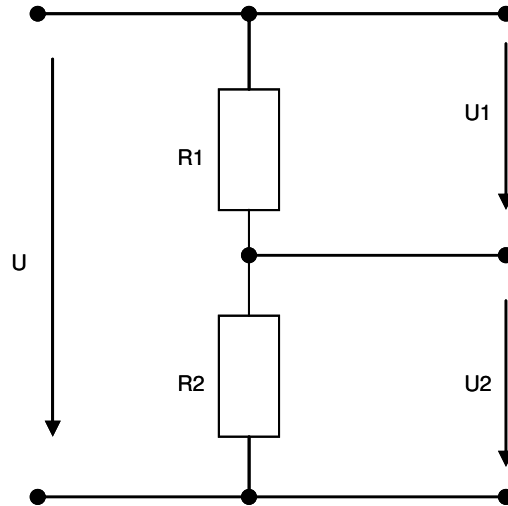

figure 2: simplified demonstration of a voltage divider

The reference voltage from the TIA ($U_{Vref(TIA)}$) is the result of the following voltage divider rule:

$$\frac{U_{Vref(TIA)}}{U_{Vref}} = \frac{R_4}{(R_4 + R_2)} \quad [V] \quad (4)$$

The calculation of all other parameters in table 6 is analog to the approach under table 5.

Sensor Signal Measurement Chain

3. Calculations based on Illuminance

A typical example to show the interrelationships of the calculation basics are shown the following picture (figure 3).

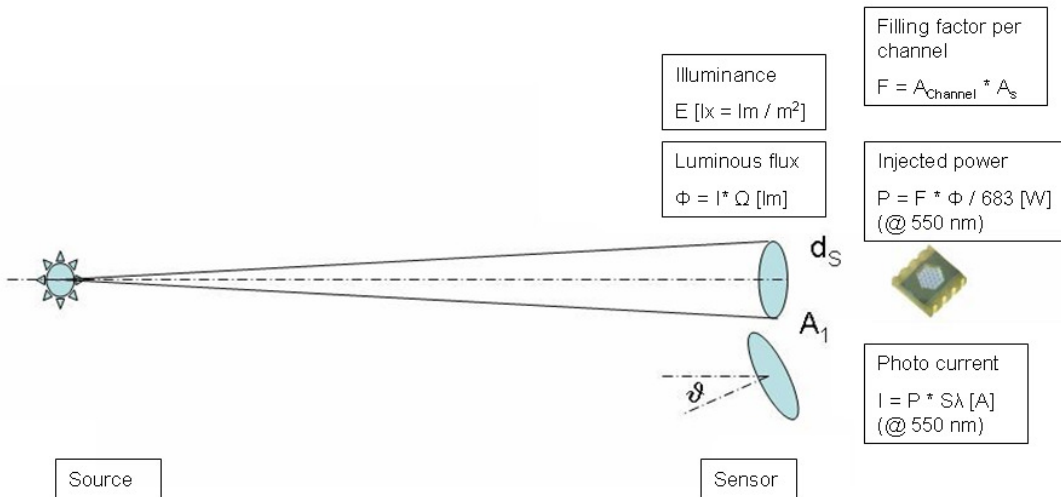

figure 3: calculation basics from illuminance to diode current

3.1 Explanations for the calculation

This Chapter explains the several areas of the Excel sheet together with its functions. The several Chapters are structured into the following points for a better understanding. The underlined values could be changed for a better practical result. The remaining values are several fix or they are recalculated after changing the underlined ones.

3.1.1 Geometric Calculations

The fix value of table 7 is the sensor diameter $d(\text{Sensor})$. The sensor area $A(\text{Sensor})$ is the result out of the diameter.

Geometric Calculations

$d(\text{sensor})$	d_s	<u>2</u> mm
$A(\text{sensor})$	A_s	3,14 mm ²

table 7: illuminance: geometrical parameters

Sensor Signal Measurement Chain

3.1.2 Photometric Calculations

Changeable values of the photometric calculations are the illuminance and the sensor dumping.

photometric calculations		
illuminance	E	<u>100</u> lx
Sensor dumping	ϑ	<u>0,00</u> °
		3,1400E-
Luminous flux	Φ	04 lm

table 8: illuminance: photometrical parameters

The illuminance is the ratio of incident luminous flux per detection area. After the conversion of the equation, the luminous flux could be calculated by a preset illuminance value. According to the sensor dumping a luminous flux (like the upper example) could be calculated.

3.1.3 Energy Calculations

The different parameter values: filling factor, mean spectral sensitivity and RGB- segmentation of the spectrum via filters are sensor specific parameters.

The filling factor is the ratio of the whole sensor area (A_S) and the area of the chosen diode. The filling factor is formed (in case of the MTCSI) of three diode channels, each with an area of 25 % of the whole area, and 25 % of non photosensitive structures.

The RGB- segmentation value (40 %) is allowed for the filter effects, which are coupling only a spectral part from approx. 40 % into the photodiodes. The value of the mean spectral sensitivity results from the sensor specific data sheet.

Energy Calculations

Filling factor	F	<u>25%</u>
Injected power	P	2,8242E-07 W
RGB- segmentation of the filters	T	<u>40%</u>
Mean spectral sensitivity	S	<u>0,3</u> A/W
Photo current	I	3,3891E-08 A

table 9: illuminance: energy parameters

The injected power P at one diode channel is the result of the multiplication from the luminous flux to the sensor area and the sensor specific filling factor. Additional to this, the result is divided by the luminous efficacy of radiation (683 lm/W) to convert the photometrical value into a physical one.

Sensor Signal Measurement Chain

The photo current is the result of the multiplication from injected power, mean spectral sensitivity and RGB- segmentation. Because of some simplifications in the following equations the results are as only approximations.

3.1.4 Electrical Calculations

Individually adjustable parameters by the transimpedance amplifier method are the resistor value, possibly the re-amplification, the reference voltage of the ADC and the resolution of the ADC.

Electrical Calculations

Analysis of the Current-Charge Converter

Capacitance	C	5,00E-11	F
Integration time	t	0,01	s
Voltage difference	U(int)	2,34E-01	V

Analysis of the TIA

Reference voltage of the ADC	VREF	2,500	V
Resistor value	R	20.000.000	Ohm
Re-amplification	N	50	

Voltage after TIA	VTIA	2,477	V
Voltage difference	ΔV	0,023	V
Output voltage	VOUT	1,169	V

ADC resolution	Res	12	bit
Reference voltage	Vref	2,5	V
digital value	ADC-Value	1915	Digits

table 10: illumination: electrical calculations

The signal voltage after the TIA is the result from the multiplication from the resistor value and the injected photo current (Chapter 3.1.3). The result out of the inverted resistor amplification function and an increasing diode current is a decreasing voltage level proportional to the reference voltage value. The following amplification stage should be configured as a differential amplifier. Note that the output voltage shouldn't leave the workspace of the ADC.

The following formula was the calculation basic for the digital values. (The result was rounded down):

Sensor Signal Measurement Chain

$$\text{ADCValue} = \left(\frac{\text{Output Voltage}}{\text{Reference Voltage}} \right) * 2^{\text{ResolutionADC}} \quad [\text{Digits}] \quad (3)$$

At method with the current charge converter only the capacitor value and the integration time could be changed individually by the user. The resulting voltage difference (U_{int}) is calculated by:

$$U_{\text{int}} = \frac{I * t}{C} \quad [\text{V}] \quad (4)$$

3.1.5 Details about the tolerance limit

The details about the tolerance limit analysis are equal to [chapter 2.1.5](#).

Sensor Signal Measurement Chain

4. Calculations based on luminous intensity

A typical example to show the interrelationships of the calculation basics are shown the following picture (figure 4).

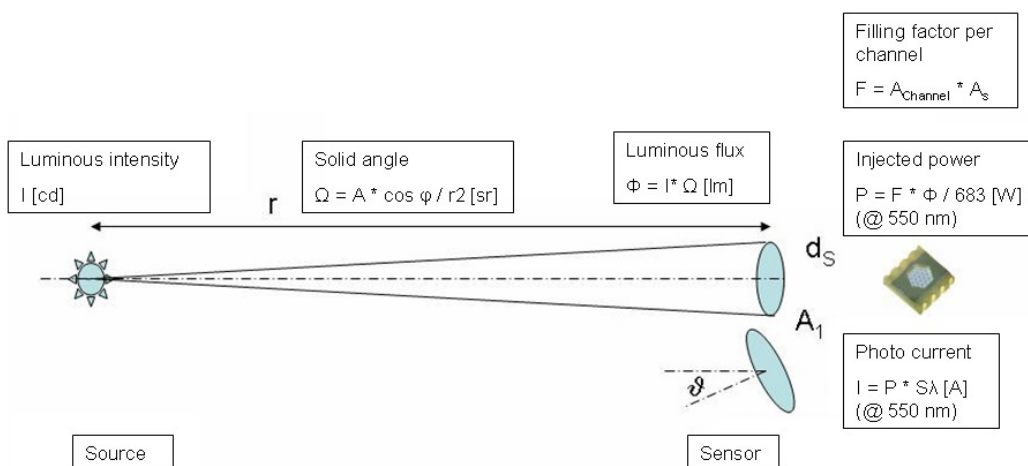

figure 4: calculation basics from luminous intensity to diode current

4.1 Explanations for the calculation

This Chapter explains the several areas of the Excel sheet together with its functions. The several Chapters are structured into the following points for a better understanding. The underlined values could be changed for a better practical result. The remaining values are several fix or they are recalculated after changing the underlined ones.

4.1.1 Geometric Calculations

Free adjustable values of table 11 are the sensor diameter $d(\text{Sensor})$ and the resulting sensor area $A(\text{Sensor})$ out of it as soon as the distance r between the source and sensor.

The distance r is only relevant for the photometrical calculation of the solid angle.

Geometric Calculations

$r(\text{Source Sensor})$	r	<u>100</u> mm
$d(\text{Sensor})$	d_s	<u>2</u> mm
$A(\text{Sensor})$	A_s	3,14 mm ²

table 11: luminous intensity: geometrical parameters

4.1.2 Photometric Calculations

Changeable values of the photometric calculations are luminous intensity and sensor dumping.

Regarding to expanded light sources, the luminescent area corresponds to the aperture level. I.e. the principle adjustment with a fix aperture is independent from the distance to the luminance area.

Sensor Signal Measurement Chain

The luminance of the aperture area (A_B) is combined to an idealized point source whose uniformly distributed illumination is radiating to the sensor adjusted half space. From this illumination the luminous flux of the sensor, which is located in the solid angle Ω , can be calculated. The solid angle is the result of the following equation: (ϑ is the sensor dumping)

$$\Omega = \frac{A(\text{sensor}) \cdot \cos \vartheta}{(r_{\text{sensor-aperture}})^2} \text{ [sr]} \quad (2)$$

Fotometric Calculations

Luminous intensity	I	<u>1</u> cd
Sensor dumping	ϑ	<u>0.00</u> °
Solid angle	Ω	0,00031 sr 3,1400E-
Luminous flux	Φ	04 lm

table 12: luminous intensity: photometrical parameters

4.1.3 Energy Calculations

The different parameter values: filling factor, mean spectral sensitivity and RGB- segmentation of the spectrum via filters are sensor specific parameters.

The filling factor is the ratio of the whole sensor area (A_S) and the area of the chosen diode. The filling factor is formed (in case of the MTCSi) of three diode channels, each with an area of 25 % of the whole area, and 25 % of non photosensitive structures.

The RGB- segmentation value (40 %) is allowed for the filter effects, which are coupling only a spectral part from approx. 40 % into the photodiodes. The value of the mean spectral sensitivity results from the sensor specific data sheet.

Energy Calculations

Filling factor	F	<u>25%</u>
Injected power	P	2,8242E-07 W
RGB- segmentation of the filters	T	<u>40%</u>
Mean spectral sensitivity	S	<u>0.3</u> A/W
Photo current	I	3,3891E-08 A

table 13: luminous intensity: energy parameters

Sensor Signal Measurement Chain

The injected power P at one diode channel is the result of the multiplication from the luminous flux to the sensor area and the sensor specific filling factor. Additional to this, the result is divided by the luminous efficacy of radiation (683 lm/W) to convert the photometrical value into a physical one.

The photo current is the result of the multiplication from injected power, mean spectral sensitivity and RGB- segmentation. Because of some simplifications in the following equations the results are as only approximations.

Sensor Signal Measurement Chain

4.1.4 Electrical Calculations

Individually adjustable parameters by the transimpedance amplifier method are the resistor value, possibly the re-amplification, the reference voltage of the ADC and the resolution of the ADC.

Electrical Calculations

Analysis of the Current-Charge Converter

Capacitance	C	<u>5,00E-11</u> F
Integration time	t	<u>0,005</u> s
Voltage difference	U(int)	1,38E+00 V

Analysis of the TIA

Reference voltage of the ADC	VREF	<u>2,500</u> V
Resistor value	R	<u>25.000</u> Ohm
Re-amplification	N	<u>1</u>

Voltage after TIA	VTIA	2,500 V
Voltage difference	ΔV	0,000 V
Output voltage	VOUT	0,000 V

ADC resolution	Res	<u>12</u> bit
Reference voltage	Vref	2,5 V
digital value	ADC-Value	0 Digits

table 14: luminous intensity: electrical calculations

The signal voltage after the TIA is the result from the multiplication from the resistor value and the injected photo current (Chapter 4.1.3). The result out of the inverted resistor amplification function and an increasing diode current is a decreasing voltage level proportional to the reference voltage value. The following amplification stage should be configured as a differential amplifier. Note that the output voltage shouldn't leave the workspace of the ADC.

The following formula was the calculation basic for the digital values. (The result was rounded down):

$$\text{ADCValue} = \left(\frac{\text{Output Voltage}}{\text{Reference Voltage}} \right) * 2^{\text{ResolutionADC}} \quad [\text{Digits}] \quad (3)$$

Sensor Signal Measurement Chain

At method with the current charge converter only the capacitor value and the integration time could be changed individually by the user. The resulting voltage difference (U_{int}) is calculated by:

$$U_{\text{int}} = \frac{I * t}{C} \quad [\text{V}] \quad (4)$$

4.1.5 Details about the tolerance limit

The details about the tolerance limit analysis are equal to [chapter 2.1.5](#).

Sensor Signal Measurement Chain

5. Calculations based on Remission

A typical example to show the interrelationships of the calculation basics are shown the following picture (figure 5).

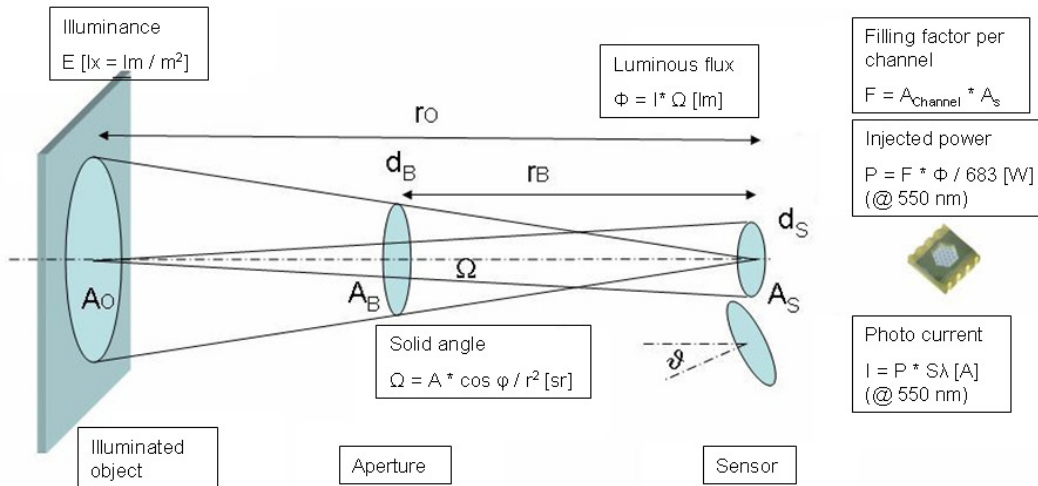

figure 5: calculation basics from remission to diode current

5.1 Explanations for the calculation

This Chapter explains the several areas of the Excel sheet together with its functions. The several Chapters are structured into the following points for a better understanding. The underlined values could be changed for a better practical result. The remaining values are several fix or they are recalculated after changing the underlined ones.

5.1.1 Geometric Calculations

Free adjustable values are the aperture diameter (and the resulting aperture area out of it), the sensor diameter (and the resulting sensor area out of it), the distance r (sensor-aperture) as soon as the distance r (sensor-object). To calculate the area A (object) of the object the following formula was uses:

$$A(\text{object}) = \frac{3,14}{4} \cdot \left[\frac{r_{(\text{sensor-object})}}{r_{(\text{sensor-aperture})}} \cdot d(\text{aperture}) \right]^2 \quad [\text{mm}^2] \quad (6)$$

All other values are calculated after the manual input the named parameters

Geometric calculations

d(aperture)	d_B	<u>2.3</u> mm
A(aperture)	A_B	4,15265 mm ²
r(sensor-aperture)	r_B	<u>14</u> mm
Beam width	φ	9,5 °

Sensor Signal Measurement Chain

r(sensor-object)	r_o	<u>14</u> mm
A(object)	A_o	4,15265 mm ²
d(sensor)	d_s	<u>2</u> mm
A(sensor)	A_s	3,14 mm ²

table 15: remission: geometrical parameters

The conversion of the color filtering is based on interference filters which had a defined combination of low and high refracting thicknesses. In case of non vertical incident light the optical path through the interference filter thicknesses is longer. So that, another composition of the interference, different to vertical incident light, is possible. Note, that the beam width φ should be smaller than 10°.

$$\varphi = \arcsin \frac{\text{aperture diameter}}{r_{(\text{sensor-aperture})}} \quad [^\circ] \quad (1)$$

5.1.2 Photometric Calculations

Free adjustable values for the photometrical calculations are the illuminance and the sensor dumping.

Photometric Calculations

Illuminance at the object	E	<u>100000</u> lx
Luminous flux at the aperture area	Φ	0,02408101 lm
Sensor dumping	ϑ	<u>0,00</u> °
Solid angle	Ω	0,01602 sr
Luminous flux at the sensor	Φ	0,00077158 lm

table 16: remission: photometrical parameters

The luminous flux at the aperture area is the ratio out of the illuminance at the object to its area.

Regarding to expanded light sources, the luminescent area corresponds to the aperture level. I.e. the principle adjustment with a fix aperture is independent from the distance to the luminance area.

The luminance of the aperture area (A_B) is combined to an idealized point source whose uniformly distributed illumination is radiating to the sensor adjusted half space. From this illumination the luminous flux of the sensor, which is located in the solid angle Ω , can be calculated. The solid angle is the result of the following equation: (ϑ is the sensor dumping)

$$\Omega = \frac{A(\text{sensor}) \cdot \cos \vartheta}{(r_{\text{sensor-aperture}})^2} \quad [\text{sr}] \quad (2)$$

Sensor Signal Measurement Chain

5.1.3 Energetische Berechnungen

The different parameter values: filling factor, mean spectral sensitivity and RGB- segmentation of the spectrum via filters are sensor specific parameters.

The filling factor is the ratio of the whole sensor area (A_S) and the area of the chosen diode. The filling factor is formed (in case of the MTCSi) of three diode channels, each with an area of 25 % of the whole area, and 25 % of non photosensitive structures.

The RGB- segmentation value (40 %) is allowed for the filter effects, which are coupling only a spectral part from approx. 40 % into the photodiodes. The value of the mean spectral sensitivity results from the sensor specific data sheet.

Energy Calculations

Filling factor	F	25%
Injected power	P	9,7404E-09 W
RGB- segmentation of the filters	T	40%
Mean spectral sensitivity	S	0,3 A/W
Photo current	I	1,1689E-09 A

table 17: remission: energy parameters

The injected power P at one diode channel is the result of the multiplication from the luminous flux to the sensor area and the sensor specific filling factor. Additional to this, the result is divided by the luminous efficacy of radiation (683 lm/W) to convert the photometrical value into a physical one.

The photo current is the result of the multiplication from injected power, mean spectral sensitivity and RGB- segmentation. Because of some simplifications in the following equations the results are as only approximations.

5.1.4 Electrical Calculations

Individually adjustable parameters by the transimpedance amplifier method are the resistor value, possibly the re-amplification, the reference voltage of the ADC and the resolution of the ADC.

Electrical Calculations

Analysis of the Current-Charge Converter

Capacitance	C	5,00E-11 F
Integration time	t	0,01 s

Sensor Signal Measurement Chain

Voltage difference	U(int)	2,34E-01 V
Analysis of the TIA		
Reference voltage of the ADC	VREF	2,500 V
Resistor value	R	20.000.000 Ohm
Re-amplification	N	50
Voltage after TIA	VTIA	2,477 V
Voltage difference	ΔV	0,023 V
Output voltage	VOUT	1,169 V
ADC resolution	Res	12 bit
Reference voltage	Vref	2,5 V
digital value	ADC-Value	1915 Digits

table 18: remission: electrical calculations

The signal voltage after the TIA is the result from the multiplication from the resistor value and the injected photo current (Chapter 5.1.3). The result out of the inverted resistor amplification function and an increasing diode current is a decreasing voltage level proportional to the reference voltage value. The following amplification stage should be configured as a differential amplifier. Note that the output voltage shouldn't leave the workspace of the ADC.

The following formula was the calculation basic for the digital values. (The result was rounded down):

$$\text{ADCValue} = \left(\frac{\text{Output Voltage}}{\text{Reference Voltage}} \right) * 2^{\text{ResolutionADC}} \quad [\text{Digits}] \quad (3)$$

At method with the current charge converter only the capacitor value and the integration time could be changed individually by the user. The resulting voltage difference (U_{int}) is calculated by:

$$U_{\text{int}} = \frac{I * t}{C} \quad [\text{V}] \quad (4)$$

5.1.5 Details about the tolerance limit

The details about the tolerance limit analysis are equal to [chapter 2.1.5](#).

---- END----